



## MODULAR TRACTION SUBSTATIONS

■ CITY ELECTRIC TRANSPORT ■

## ABOUT COMPANY

PLUTON is the modern innovative manufacturer of electrotechnical equipment for city electric transport, metro and railways. The Company holds key positions in electrical industry and has been successfully working over 30 years implementing the strategy of intensive growth, development and continuous improvement of products and services quality.

More than 70 types of PLUTON equipment are supplied to various countries of the world and successfully applied in the field of transport, power industry and production sector. PLUTON Group has representative offices in 7 countries and continues to develop dynamically and extend its global presence.

PLUTON confirmed compliance of its management principles with international standards of quality management system ISO 9001:2015, Environmental Safety ISO 14001:2015, as well as occupational safety and health ISO 45001:2018 requirements.

Due to our vast experience and innovative technologies, we provide secure, reliable and efficient power distribution. We are building the future, creating products of up-to-date level in compliance with the international standards that ensure safety and comfort of Customers.

We provide a full range of services: from design up to installation and commissioning of the supplied equipment on operation site. Furthermore, we provide the following services after equipment start-up:

- personnel correct and safe operation and maintenance training;
- warranty and post-warranty maintenance;
- spare parts supply.

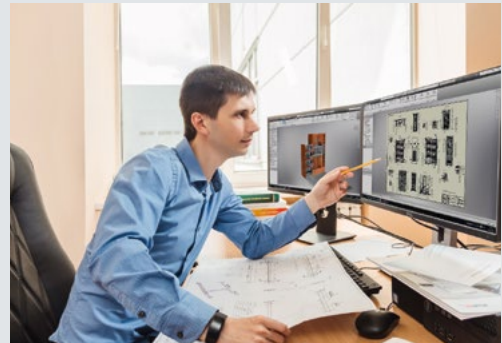

## MODULAR TRACTION SUBSTATIONS

Aiming to improve quality and reliability of electric power supply, PLUTON offers integrated solutions for construction of modern modular traction substations. This solution opens prospects and horizons for development of a functionally complete facility for power supply of the first category consumers with flexible configuration according to design features.

Modular traction substation can be used as transportable or fixed electric power distribution points. Modular traction substation refers to 6-20 kV voltage class and is designed for operation in automatic mode, being an unattended installation.

Application of modern equipment and advanced solutions in the field of electrical engineering, based on years of experience, ensures safety and reliability in equipment operation.

Modular traction substation is a functionally finished product with organization of power and secondary circuits connections. Modules are mechanically unrelated, and are installed in accordance with the design solution. Modular traction substation is perfect for any project where it's necessary to reduce the scope of site works.



# BENEFITS OF MODULAR TRACTION SUBSTATION

## Efficiency and cost saving

- / minimum scope of civil works at the site, optimization of the required space, no time and costs needed for capital construction;
- / high degree of substation readiness for commissioning, quick installation (simple connection of primary and secondary circuits). All this allows to install substations of any complexity at the shortest possible time;
- / saving of time and maintenance costs during substation operation by application of high-quality and reliable components.

## Maintenance

- / easy access to equipment and components;
- / modular approach and interchangeability of withdrawable components for faster and easier maintenance and diagnostics.



## Safety

- / installation of electrical equipment, integrated adjustment, laying engineering networks within the module, as well as substation tests are done at the manufacturer and this allows to achieve high quality, safety and reliability of substation;
- / modular traction substation equipment is designed in accordance with international requirements and standards, current norms and rules, including rules of fire and explosion safety;
- / reduction of equipment damage and personnel injury risk by means of equipment status control automation and guaranteed safety of routine switching.

## Flexibility

- / object-focused approach to project implementation of any complexity, possibility to configure various schemes and wide selection of modules installation and layout options;
- / mobility and possibility of transportation to a new operating site by road and rail;
- / application of modules various color solutions depending on the Customer requirements and possibility to adapt substation appearance to architectural requirements.



# DESIGN OF MODULAR TRACTION SUBSTATION

Modular traction substation can be:

- single-unit — one unified module;
- two-unit — two unified modules;
- three-unit — three unified modules.

Manufacturing of modular traction substation for a more number of units is possible in case of necessity.

Modules have robust structure, designed for electrical installations weighing up to 12 tons in each. The modules are dust and moisture-resistant with IP55 protection level in accordance with IEC 60529 (except ventilation grilles in opened operation position). Substation modules are faced and lined with steel sheet with protective coating resistant to external action. Modules floor, walls and roof are heat-insulated.

Facing and finishing materials are fire-resistant and fireproof. All metal parts of modules are protected against corrosion. Each module is equipped with ladders, door canopies and drain. The substation is equipped with facilities for loading and unloading, as well as spare tools and accessories kit.

Non-toxic and nonhazardous during operation materials are used in development and manufacture of modules in order to prevent negative impact on the environment. The materials are also resistant to climatic factors, high temperature, open flames and solar radiation.



READY-TO-OPERATE  
MINIMUM CONSTRUCTION SCOPE

Structurally, each module is divided into several compartments: transformer compartments and switchgear compartment. Equipment in modules is placed according to functional groups.

Each module has external devices to connect to protection earthing circuit.

Modular traction substation can be equipped with a service module, amenities, module-workshop and module-warehouse necessary for maintaining the substation.

Operating conditions:

Modular traction substation operation is provided under the following climatic conditions (acc. to IEC/EN 62271-202):

- altitude — up to 1000 m;
- ambient temperature operating limits:
  - upper — plus 40 °C;
  - lower — minus 40 °C.



# MODULAR TRACTION SUBSTATION EQUIPMENT

AIR CONDITIONING SYSTEM



VENTILATION SYSTEM



ELECTRIC HEATING SYSTEM



LIGHTING SYSTEM



FIRE ALARM SYSTEM



INTRUDER ALARM SYSTEM



## DC SWITCHGEAR

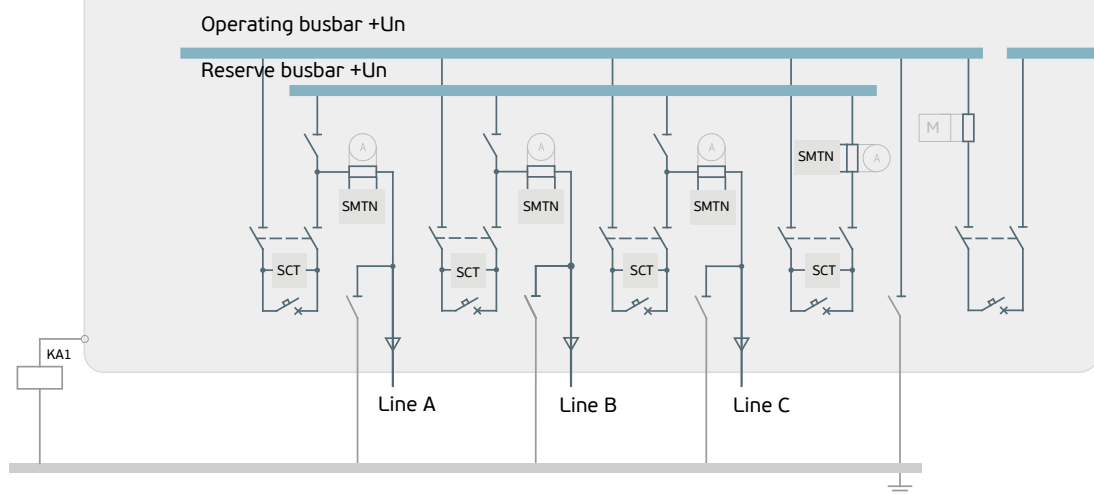

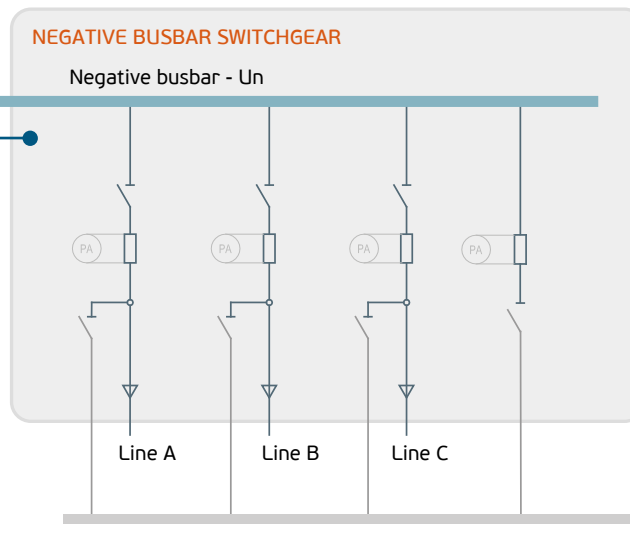
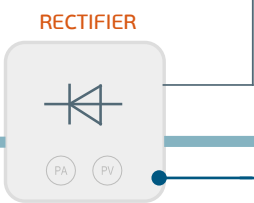
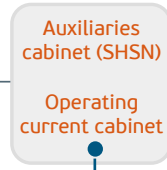
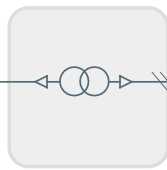
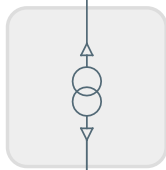
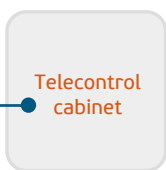
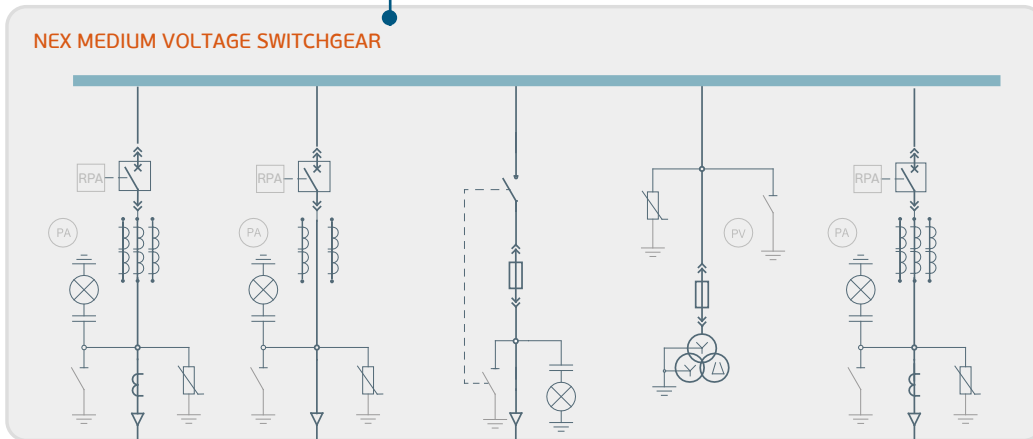



# MODULAR TRACTION SUBSTATION EQUIPMENT

Modular traction substation includes necessary and sufficient set of modern equipment, its parameters and functions meet requirements of the main international and European standards IEC/EN 62271-1 and IEC/EN 62271-202.

## Benefits of modular traction substation equipment

- / long-term equipment life cycle and high level of technical and operational characteristics due to application of high-quality, reliable and safe components;
- / minimization of maintenance, saving of time and costs on routine and major maintenance;
- / maintainability and personnel safety;
- / rightsizing of personnel due to implementation of automatic control technologies. The substation maintenance is limited only to periodic technical inspections and does not require constant presence of personnel;
- / power breaks time minimization, reduction of equipment downtime and the time between beginning of fault and its elimination due to equipment monitoring and diagnostics.

Modular traction substation can be equipped with fixed or withdrawable rectifiers.

Withdrawable rectifiers are installed into a DC-board with DC switchgear. It's the most effective approach to traction substations architecture that provides:

- / compact arrangement of traction equipment set;
- / extra space saving inside the modular traction substation due to comprehensive single-sided maintenance;
- / optimization of costs on materials and installation works due to minimum space between rectifier and DC switchgear;
- / fast operation, as well as easy diagnostics and maintenance of DC switchgears and rectifier due to modular approach and interchangeability of their withdrawable components.

Rectifiers can be manufactured with 6-pulse and 12-pulse bridge rectification circuit (by agreement with the Customer).



# MODULAR TRACTION SUBSTATION EQUIPMENT

## Lighting system

Modular traction substation is equipped with fixed and emergency lighting system with energy saving lamps. Lighting is provided inside and outside modular traction substation.

## Ventilation, air conditioning, heating systems

Modular traction substation is equipped with supply and exhaust ventilation, controlled by microclimate monitoring unit. Shutters for natural ventilation are installed. The shutters can be closed with electric drive. There is also a possibility of manual control. The shutters can be additionally closed with special louvers in cold season. Ventilation grids in operating position are vermin-proofed.

Air-conditioning system is provided (air cooling and heating without condensation). An outdoor air conditioner unit is installed outside, mainly on the narrow side of modular traction substation. Indoor unit is installed under switchgear compartment ceiling.

Combined operation of ventilation and air conditioning systems provides a range from plus 5 °C to plus 28 °C air temperature inside modular traction substation. In cold season, the specified air temperature range inside the substation is provided by electric heating system.

Ventilation, air conditioning and heating systems components, as well as places for their installation, are selected based on heat dissipation and equipment layout plan in the module.





## Intruder alarm and fire alarm system

Modular traction substation is equipped with intruder alarm and fire alarm system. Fire-extinguishing means are located inside.

Doors and gates are equipped with door locks with a possibility of the doors and gates opening from the inside. Unauthorized intrusion into modular traction substation is difficult due to usage of strengthened door hinges, reliable locks and alarm system.

## Additional equipment

Power tools can be connected for assembly and repair works in modular traction substation. Modular traction substation is equipped with personal protective tools and measuring equipment (on the Customer's request).



## Warranty of equipment safe operation

Protective fixed and temporary fencing, workplace isolation, protective shutdown, interlockings and safety signs are provided to ensure protection against accidental contacting live parts at the substations. The following methods are used for protection against electric shock by touching metal non-conducting parts, which can be live in case of insulation damage: protective grounding, neutralling, potential leveling, protective conductors system, protective shutdown, insulation of non-conducting parts, electric network isolation, insulation control, personal protective equipment.

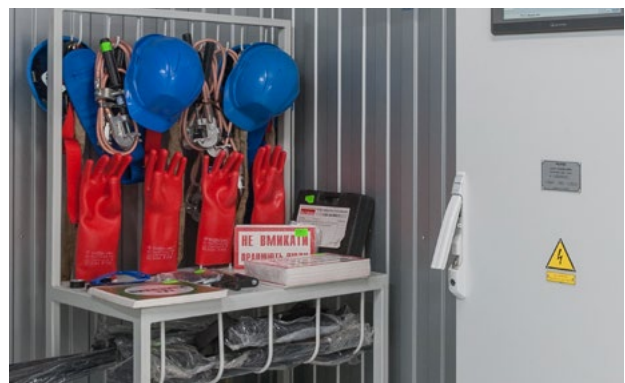



# MODULAR TRACTION SUBSTATION EQUIPMENT

## Telecontrol system

Reliable power supply is provided by modern traction equipment system automatically controlled by telecontrol system.

Modern integrated telecontrol system provides:

- operational monitoring of modular traction substation equipment state and operation modes, substation equipment control and timely switching in standard and emergency situations;
- continuous logging of equipment controlling personnel actions, fixing various events on equipment status and telecontrol system operation, retrospective of necessary parameters and data;
- full-scale diagnostics of all system units, hardware and data channels functioning;
- data level compatibility with different upper-level systems based on open technologies and open data exchange protocols;
- high uninterrupted system operation and fail safety due to components and communication channels «hot» backup principle.



INTEGRATED CONTROL, MONITORING AND PROTECTION OF SUBSTATION EQUIPMENT

Substation equipment is controlled, monitored and protected by modern telecontrol cabinet equipped with backup controllers, that comply international standards of IEC 61131 series supporting data transfer protocol in accordance with international and European standards IEC/EN 61850, IEC/EN 60870, IEC/EN 62351 in part of security, reliability and quality.

Telecontrol cabinet provides the following main functions:

- / receiving of discrete signals on the substation equipment state;
- / telecontrol signals generation;
- / information exchange with substation equipment via modern industrial communication channels;
- / data exchange with power operator telecontrol cabinet.



Telecontrol cabinet panel computer is used as the substation operator automated workstation and provides:

- displaying of substation single line diagram indicating state of all switching devices and measured electrical values;
- switching devices control;
- information in form of tables, graphs, trends;
- reading of current and retrospective events;
- generation of reporting documents.

# MODULAR TRACTION SUBSTATION TRANSPORTATION AND INSTALLATION

Modular traction substation can be transported on platforms by road and/or rail. The module design provides facilities for usage of lifting devices. Modules indoor equipment is not removed. Switchgear trolleys, ladders, drain, air conditioning system outdoor unit are transported separately.

Such an installation allows fast mounting and dismantling, moving to a new operation place. This allows significantly to reduce the time and effort required for modular traction substation commissioning. The design provides easy connection of external communications.

Modular traction substation is installed on a prepared site on the foundation (reinforced concrete blocks or other support elements).

Modular traction substations are equipped with ladders for easy operation.

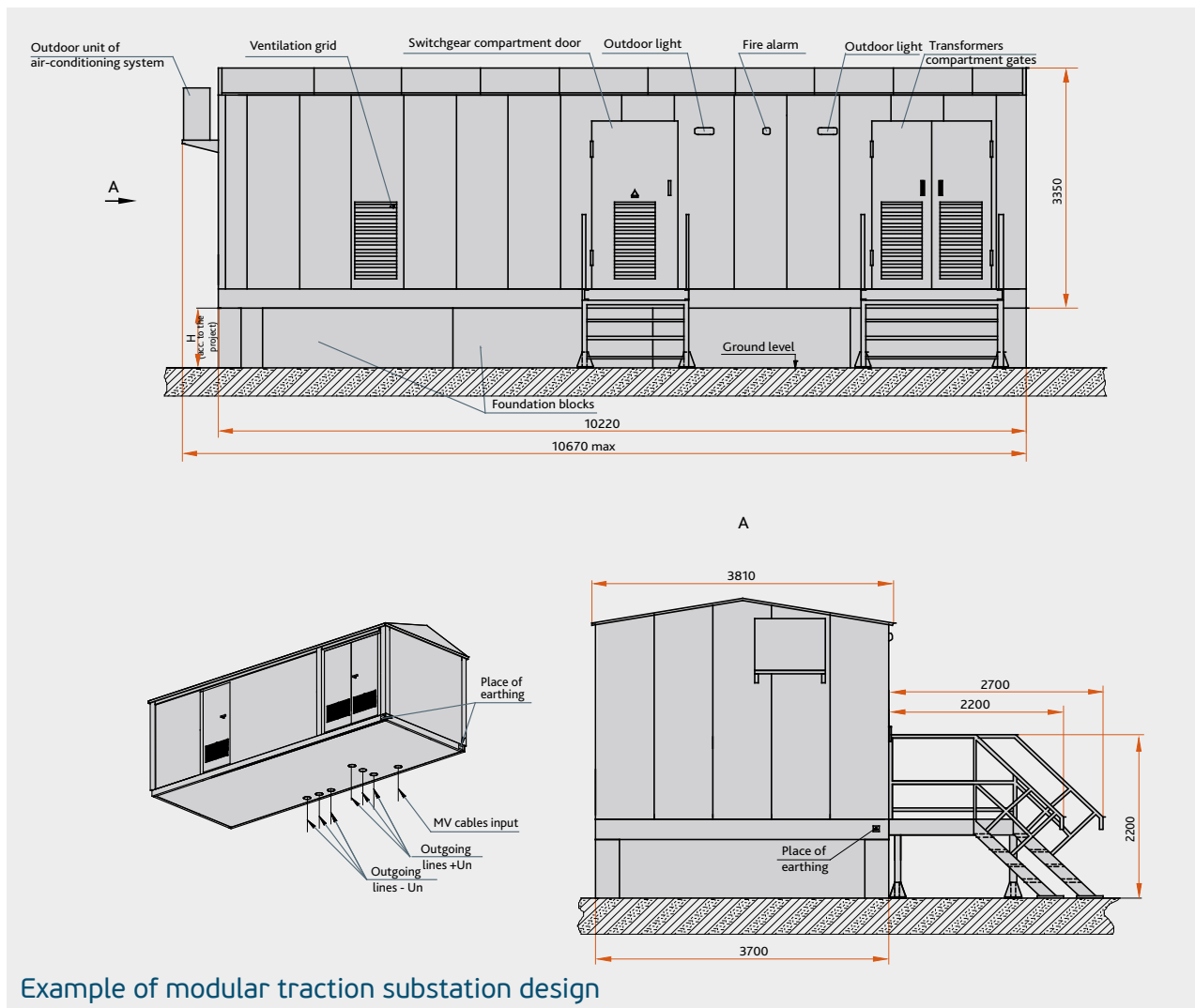

Example of modular traction substation design

## MAIN TECHNICAL CHARACTERISTICS OF MODULAR TRACTION SUBSTATION

<b>Technical parameters</b>		
Rated voltage on HV side	kV	6; 10; 15, 75; 17.5; 20
Number of high voltage inputs	unit	one/two/three
Number of traction transformers	unit	one/two/three
Type of traction transformers	-	Dry (type of windings: cast resin, RESIBLOC®, RESIGLAS)
Rated power of traction transformer	kVA	630 ... 2000 - internal, up to 10000 - free-standing
Rated voltage of traction network	V	600, 660, 750, 1500
Rated current of outgoing feeders	A	1000; 2000
Number of rectifiers	unit	one/two/three
Rectifier circuit	-	Bridge (6-, 12-pulse)
Connections diagram number (EN 50328)	-	8-9-12
Rectifier duty class (IEC 60146-1-1, EN 50328)	-	IV, V, VI
Rated current of busbars on HV side	A	up to 2500
Rated current of busbars on LV side	A	up to 6000
Short time thermal current on HV side	kA/s	25
Short time withstand current on HV side	kA	62.5
Short time withstand current on LV side	kA	80
Rated frequency	Hz	50
Rated voltage of secondary circuits:	V	
- AC		380, 220
- DC		220 (110)
<b>Configuration</b>		
Number of output feeders for:	unit	
- 1 unit		1...3
- 2 units		3...5
- 3 units		5...8
Number of modules	unit	one/two/three
Remote control system (SCADA)	-	yes
Main standards		IEC 62271-1, IEC 62271-202, EN 60076-11, IEC 61992, EN 50123, IEC 60146-1-1, EN 50328.

Manufacturing of modular traction substation with parameters different from those given above is made upon special order.



# SERVICE

## Design works and manufacturing

- recommendations on equipment selection;
- design;
- manufacturing, installation, commissioning and overall tests at the enterprise-manufacturer;
- site and foundations preparation.



## Implementation of the project

- transportation to the site;
- substation installation on the foundation;
- connection of incoming MV cables, outgoing DC cables, intruder alarm, fire alarm systems and telecontrol;
- acceptance tests and commissioning.



## After-sales service

- training of the Customer's personnel;
- providing operational support;
- warranty and after-sales service.

# IMPLEMENTED PROJECTS

## Vinnitsya tram (Ukraine)



Supply of two-unit modular traction substation for Municipal Enterprise Vinnitsya Transport Company.

Installation, commissioning, startup.



module — 2 units;



NEX switchgear 10 kV — 1 set.;  
DC switchgear 600 V — 8 units;



rectifier — 2 units;  
converter transformer — 2 units;



auxiliaries equipment — 1 set.;



telecontrol equipment — 1 set.

# IMPLEMENTED PROJECTS

## Lviv city electric transport (Ukraine)



Supply of three-unit modular traction substation for TS-17.

Installation, commissioning, startup.



module — 3 units;



NEX Switchgear 6 kV — 1 set;  
DC Switchgear 600 V — 12 units;



rectifier — 3 units;  
transformer RESIBLOC® — 3 units;



auxiliaries equipment — 1 set.;



telecontrol equipment and SCADA system — 1 set.



## Kramatorsk city electric transport (Ukraine)



Supply of three-unit modular traction substation for Municipal Enterprise Kramatorsk Tram and Trolleybus Authority.

Development of project design and estimate documentation, installation, commissioning and startup.



module — 3 units;



NEX Switchgear 6 kV — 1 set;  
DC Switchgear 600 V — 12 units;



rectifier — 3 units;  
converter transformer — 3 units;



auxiliaries equipment — 1 set;



telecontrol equipment and SCADA system — 1 set.



# IMPLEMENTED PROJECTS

## Mykolaiv city electric transport (Ukraine)



Supply of two-unit modular traction substation for Municipal Enterprise Mykolaivelectrotrans.

Installation and commissioning supervision.



module — 2 units;



NEX Switchgear 6 kV — 1 set;  
DC Switchgear 600 V — 7 units;



rectifier — 2 units;  
converter transformer — 2 units;



auxiliaries equipment — 2 sets;



telecontrol equipment — 1 set.

## Oradea city electric transport (Romania)



Supply of two-unit modular traction substation for Cicero substation, Oradea Transport Local S.A.

Design, supply of equipment, installation supervision, commissioning.



module — 2 units;



medium voltage switchgear SM-6 20 kV — 1 set;  
DC Switchgear 750 V — 6 units;



rectifier — 2 units;  
traction transformer — 2 units;



auxiliaries equipment — 1 set;



telecontrol equipment — 1 set;  
contact network overvoltage protection unit  
OVLD — 1 unit;  
protection unit DEPEC — 1 unit.



# IMPLEMENTED PROJECTS

## Kyiv city electric transport (Ukraine)

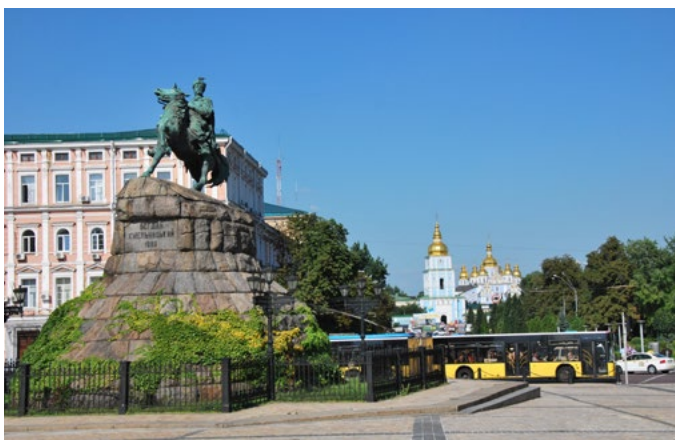

Supply of Lybidska single-unit modular traction substation and Almatynska two-unit modular traction substation for Municipal Enterprise Kyivpastrans.

Installation, commissioning and startup.



module — 3 units;



NEX Switchgear 10 kV — 2 sets;  
DC switchgear 600 V — 18 units;



rectifier — 3 units;  
converting transformer — 3 units;



auxiliaries equipment — 2 sets;



telecontrol equipment — 2 sets.

## Zgierz city electric transport (Republic of Poland)



Supply of Łąkowa two-unit modular traction substation.

Design, supply of equipment, installation, commissioning.



module — 2 units;



medium voltage switchgear 15 kV — 1 set;  
DC Switchgear 660 V — 9 units;



rectifier — 2 units;  
traction transformer — 2 units;



auxiliaries equipment — 1 set;



SCADA system — 1 set.





PLUTON Polska

44, Domaniewska str.  
02-672 Warsaw, Poland

Telephone/Fax:  
+48 22 111 50 31

E-mail: [office@pluton-polska.pl](mailto:office@pluton-polska.pl)  
[www.pluton-polska.pl](http://www.pluton-polska.pl)



LLC PLUTON IC

5 Novobudov St.  
Zaporizhzhia 69123, Ukraine

Telephone/Fax:  
+380 (61) 239-79-00  
+380 (61) 239-79-01

E-mail: [info@pluton.ua](mailto:info@pluton.ua)  
[www.pluton.ua](http://www.pluton.ua)